

PRODUCT INTRODUCTION 产品介绍

柔道超柔连续抛缩烘干机专为解决织物面料手感和预缩而设计。织物在特殊设计的风道中在无张力的状态下往复运行并被拍打，纤维在风力作用下性能发生膨胀从而获得超级柔软的手感，同时织物结构在无张力和高温状态下获得完美的预缩效果(>3%)。

JUDO soft tumble dryer is designed for Super soft, bulky hand feel and perfect Pre-shrinkage (>3%) treatment. Fabric is conveyed FOR/REV by hot air in fully tensionless status, simultaneously fabric is treated by the tumble grid to obtain an expansion of fiber. Thanks to the heat treatment to the fabric under fully tensionless status, the fabric obtains both perfect pre-shrinkage result and super soft feel!



SCHEMATIC DIAGRAM 流程图

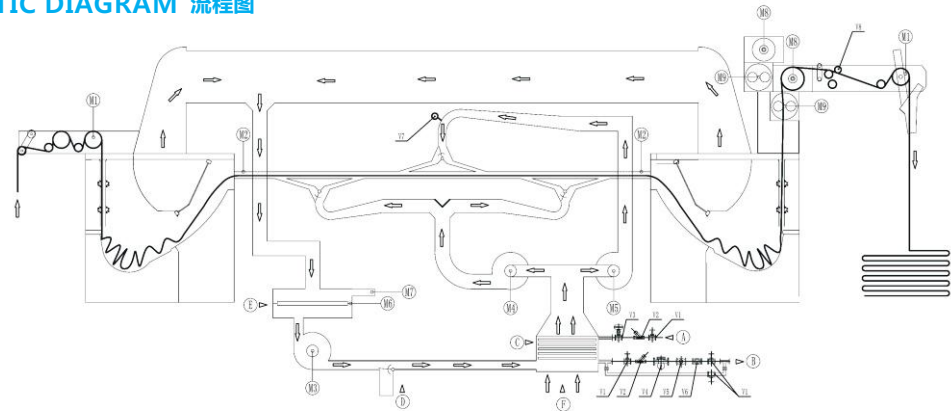

- A** Steam Inlet
蒸汽加热进口
- B** Condenser Outlet
冷凝水排水出口
- C** Heat exchangers
热交换器
- D** Air Compensation Inlet
补充空气进出口
- E** Dust box
集尘箱
- F** Hot Air Inlet
加热进风口
- M** Driving Motors
马达
- V** Valves
阀表

SPECIFICATION TABLE 规格型号

ITEM	MODEL			
	JUDO-2400	JUDO-2600	JUDO-2800	JUDO-3000
Maximum fabric width 最大工作幅宽	2400mm / single strand 单幅	2600mm / single strand 单幅	2800mm / single strand 单幅	3000mm / single strand 单幅
	1000mm / double strand 双幅	1100mm / double strand 双幅	1200mm / double strand 双幅	1300mm / double strand 双幅
	700mm / triple strand 三幅	800mm / triple strand 三幅	900mm / triple strand 三幅	960mm / triple strand 三幅
Minimum working width 最小工作幅宽	400mm (in either single, double or triple strand)			
Mechanical speed 机械速度	3-50 mt / min			
Heating system 热源	Steam / THERMO OIL / GAS			
Maximum installed thermal power 最大热量消耗	850 kw - 730.000 Kcal/h			
Maximum air temperature 最高温度	150°C / 200°C			
Steam line 蒸汽管道直径	DN50, PN16			
Steam feeding pressure 供汽压力	8-10 bar			
Average steam consumption 蒸汽消耗量	550 kg/h			
Installed power 装机容量	145 kw			
Absorbed power 实际电耗	70 kw			
Power Supply 电源规格	V 380-480, trifase, Hz 50-60			
Dimensions 体积(L x W xH)	12083 x 4622 x 3785 (mm)	12083 x 4822 x 3785 (mm)	12083 x 5022 x 3785 (mm)	12083 x 5222 x 3785 (mm)

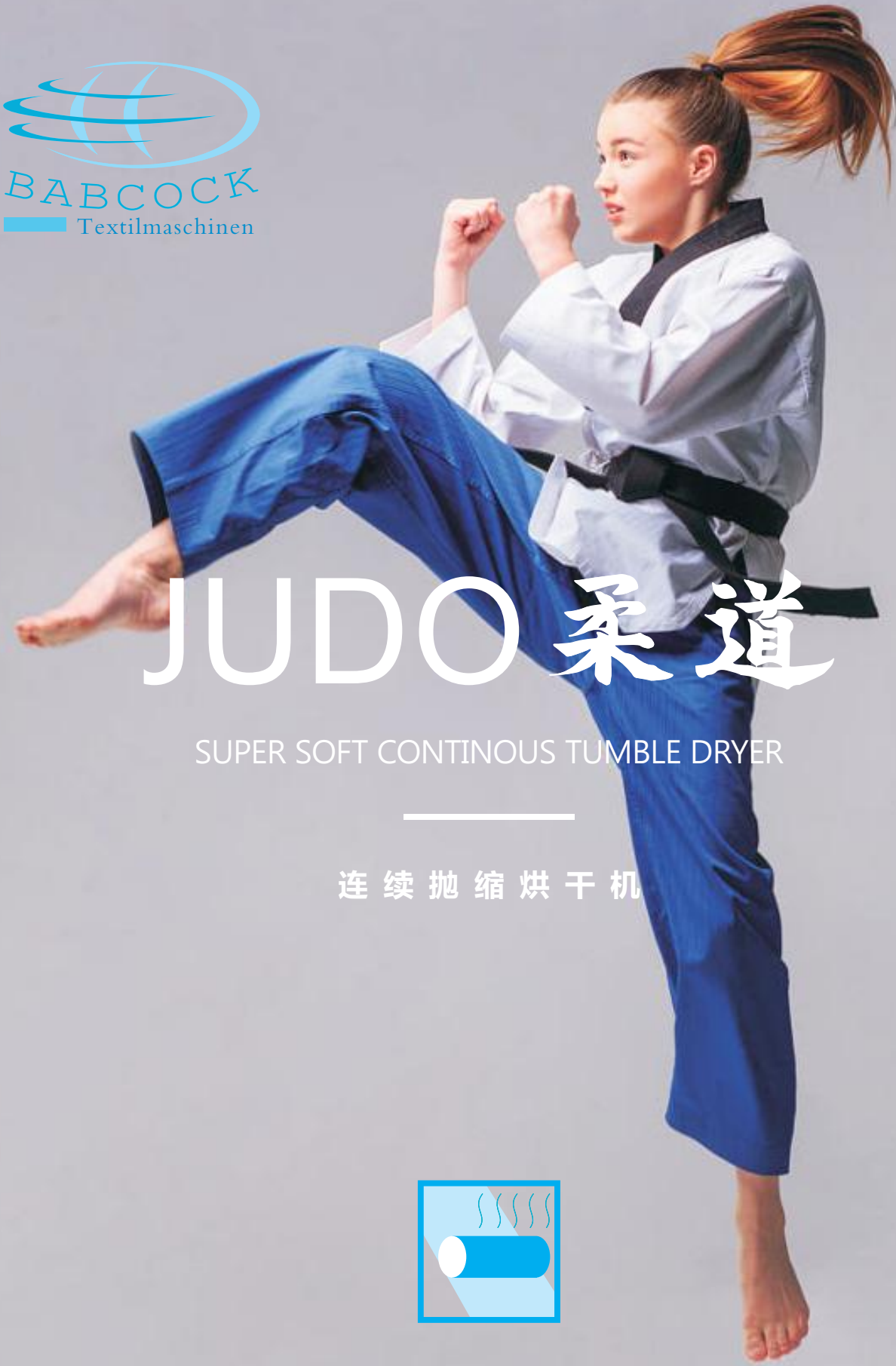

JUDO 柔道

SUPER SOFT CONTINUOUS TUMBLE DRYER

连续抛缩烘干机

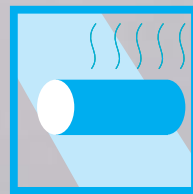

www.babcockstenter.com

B-16



BABCOCK TEXTILES MACHINERY (HUIZHOU) CO., LTD.
巴布考克纺织机械(惠州)有限公司

中国-广东省惠州市博罗县洲镇禾山工业区
Texlink Industrial Park, HeShan Village, YuanZhou Town,
BoLuo County, HuiZhou 516123, P.R.China
Tel:86-752-6650 928 Fax:+86-752-6650 298
E-mail:sales@babcockstenter.com

DISTRIBUTOR.
经销商

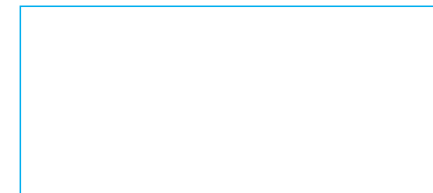

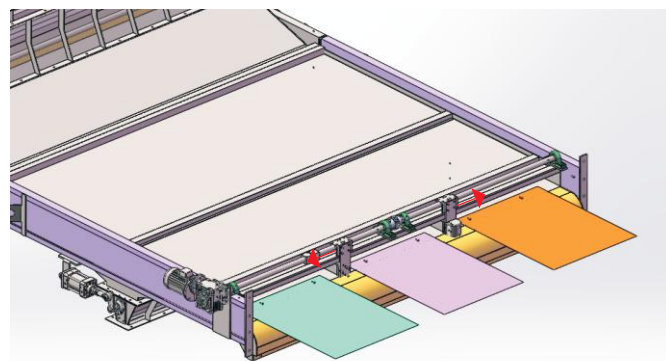

1-根据织物幅宽调节风道宽度，最大限度节能并提供最好的拍打效果。
That can adjust the shooting tunnel is internal working width according to the fabric type and the desired tumbling effect.

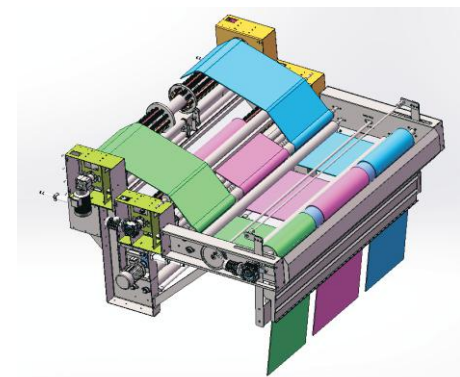

2-最多可同时处理三幅织物，尤其对于处理窄幅织物，可最大限度提高处理速度及获得最好的柔软手感。

Allow the simultaneous processing up to 3 fabric strands in continuous. This unique feature gives the operator the possibility to greatly optimize production speed when drying and softening narrow width towel fabrics.

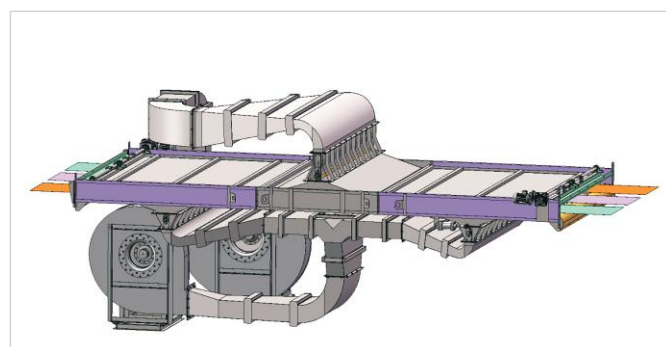
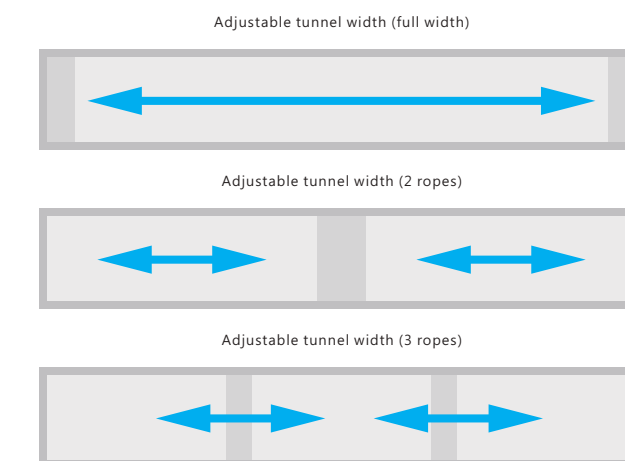

4-最佳的经向预缩效果，在撞向拍打格栅前，织物在风道中由上下两股热气流托举左右运动，处于绝对的松弛状态，从而使织物获得完美的预缩效果；并且由于织物没有与任何物体摩擦，避免起球。

Besides simply shooting the fabric to the right or to the left, the fabric can be kept floating and relaxing into the tunnel for a pre-set number of seconds between each beating and the following one. This feature allows the operator to:

- Adjust the ratio between drying and tumbling effect;
- Control precisely the number of impacts;
- Minimize warp-wise elongation;
- Preventing peeling formation;



5-BIANCO 布面湿度监测和控制系统。可检测出布的烘干效果和湿度，调整机器速度以及抽湿风机的运行，减少人工干预对质量和产能的影响。

BIANCO Fabric Surface Moisture sensing and control system maintain fabric humidity ratio and automatically adjust the speed of delivery and blowers, greatly reduced affect to quality and capacity by the operator.

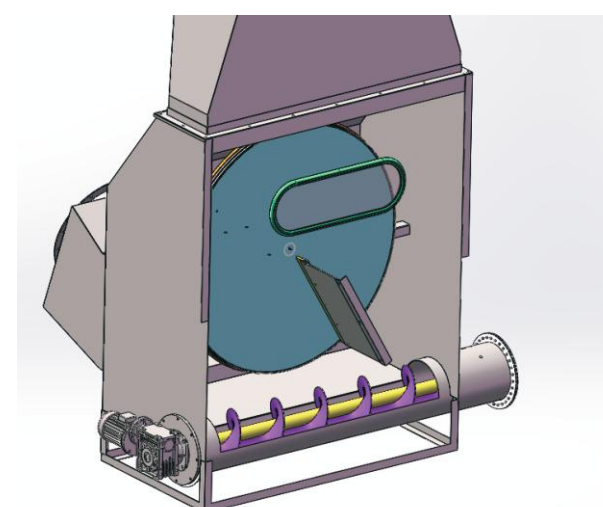

3-无飞尘处理效果，处理织物后的热风通过拍打格栅后，直接被吸入顶部的吸尘风道，通过自动过滤系统和除湿后再进入风道。经处理的织物飞尘含量降到最低水平。

Unique effect is obtained by high-speed airflows, which are accurately recovered behind the mechanical grids and directed towards the top of the machine by the exhaust fan. The generated vacuum allows the fabric to be folded uniformly in the scrays, preserving it from any possible fluff and contamination.